

MS2/MS3

World leaders in high precision magnetic field measurements

MS2/MS3

Magnetic Susceptibility System



Bartington®
Instruments



MS2/MS3

Magnetic Susceptibility System

The magnetic susceptibility system comprises a meter with a range of sensors for measuring the magnetic susceptibility of many types of material including soils, rocks, powders and liquids. It is suitable for use both in the laboratory and in the field.

Magnetic susceptibility measurements provide information about the composition and properties of materials. This is valuable in many areas of scientific investigation. For example, in UXO location, the susceptibility of soil has a strong influence on the efficiency of metal detection techniques; in palaeoclimatology, measurements on sediments can help to determine their origin and the climatic conditions at the time of deposition.

The Bartington MS2/MS3 System is a highly versatile tool. It provides the scientist with the ability to perform high precision measurements in a wide variety of different applications, including:

- Geological and soil surveys
- Palaeomagnetism
- Archaeological prospecting
- Palaeoclimatic studies
- Hydrology
- Sedimentology
- Core logging and correlation
- Soil and airborne pollution surveys
- Analysis of ferrites and magnetic inks
- Study of micro/nano magnetic particles and fluids

Sensors are available for large area field surveys, core logging, outcrops and small "bottled" samples in a laboratory. Software is supplied to integrate the system with desktop PCs, laptops and handheld GPS/PDA devices.

The Bartington MS2/MS3 System is a reliable, high quality instrument that has earned a reputation as the world standard for environmental magnetic susceptibility measurements. It is widely used by academic and research establishments in many countries.

A list of academic work undertaken using the MS2/MS3 System is available at www.bartington.com

Principle of operation

The MS2/MS3 System operates by generating a low frequency, low intensity, AC magnetic field around the sensor. When sample material is placed near the sensor, the resulting change in this field is sensed by the system and converted to magnetic susceptibility readings for both positive and negative (diamagnetic) values, to a resolution of 2×10^{-6} SI units. The measurements are non-destructive, retaining the sample's magnetic characteristics, and relatively unaffected by sample conductivity. The sensors are temperature compensated to minimise drift during use.



MS2 Magnetic Susceptibility Meter

The MS2 is a portable meter with an integral, four-digit display. It will operate with all MS2 sensors. Powered by internal batteries, it is rechargeable from the mains or a vehicle charging point, with indicators for battery status and charging. Push buttons or a toggle switch are used for zeroing or taking measurements. The serial connection can be used for control and acquisition of data. A range switch allows the user to select high or low resolution. All sockets and switches are environmentally sealed for outdoor use.

The meter is supplied with a carrying bag for field use, an instrument stand for laboratory use, a universal mains adaptor, a vehicle charger and a serial/USB converter.



MS3 Magnetic Susceptibility Meter

The MS3 is a compact, lightweight meter, offering increased performance over its predecessor, the MS2 Meter. It can measure magnetic susceptibility up to 26 SI (compared to 0.1 SI for the MS2), and the measurement period is selectable down to 0.1s minimum. The MS3 Meter provides significant advantages over the MS2 in terms of portability, configurability and connectivity to a PDA device for GPS-logged field work.

This advanced device offers USB connectivity and is completely software controlled. It must be connected to a compatible PC, laptop, PDA or mobile phone (with USB host capability), which provides all measurement control and display. The Bartsoft software supplied with the unit gives the user control over the measurement protocol and speed. It includes options to display data in both chart and table formats. Full details of Bartsoft are shown at the end of this brochure.

The MS3 operates with all MS2 sensors, including the susceptibility/temperature system. The meter is sealed and suitable for both indoor and outdoor use. For outdoor use, a rugged PDA/GPS is recommended (a fully compatible Trimble Nomad 800L PDA can be supplied).

	MS2 Meter	MS3 Meter
Range	0.09999 SI (volume specific)	26 SI (volume specific)
Maximum resolution	2×10^{-6} SI	2×10^{-6} SI
Units	SI or CGS	SI or CGS
Measurement time	1s or 10s	Selectable to 0.1s minimum
Display	Yes	No (requires PC or PDA)
Laboratory data logging	Yes (with Bartsoft or Multisus)	Yes (with Bartsoft)
Field data logging	Not available	Yes (with Bartsoft for Windows® CE)

A working system comprises a meter unit (either the MS3 or MS2) and one or more sensors.



MS2B Dual Frequency Sensor

This sensor is primarily used to measure the magnetic susceptibility of soil, rock and sediment samples. It is widely recognised as a standard instrument in the characterisation of the magnetic properties of soil. It can also be used in conjunction with the AMSWIN-BAR software and sample adaptor for measurements of the anisotropy of magnetic susceptibility in rocks.

The unique dual frequency facility permits identification of ferrimagnetic grains close to the superparamagnetic/stable single domain transition. This information is critical to many aspects of interpretation, for example in studies of weathering and soil formation, fossil soil identification and characterisation, and sediment or dust source investigations.

The MS2B is also suitable for susceptibility measurements of magnetic fluids, inks and micro/nano particles.

The sensor accepts 10ml and 20ml cylindrical bottles, 25.4mm and 23mm cubic boxes, 35mm pots and 25.4mm cylindrical cores. A calibration sample with low temperature and frequency dependency is supplied with the MS2B.

Specification - MS2B Sensor

Calibration accuracy	1% (10ml calibration sample provided)
Measurement period: x 1 range x 0.1 range	1.5s SI (1.2s CGS) 15s SI (12s CGS)
Operating frequencies: LF HF	0.465kHz \pm 1% 4.65kHz \pm 1%
Amplitude of applied field	250 μ T peak \pm 10% (LF & HF)
Maximum resolution	2 x 10 ⁻⁶ SI (vol) (2 x 10 ⁻⁷ CGS) (LF & HF)
HF/LF cross calibration	0.1% worst case (can be adjusted using calibration sample)
Temperature induced drift: sample to sensor differential	\pm 0.05 x 10 ⁻⁵ SI/ $^{\circ}$ C/minute (LF& HF) (\pm 0.05 x 10 ⁻⁶ CGS/ $^{\circ}$ C/minute)
Dimensions (H x W x D)	145 x 110 x 210mm
Weight	0.7kg
Enclosure material	High impact ABS



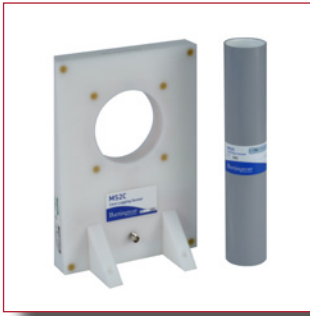

MS2C Core Logging Sensor

A series of loop sensors, ranging from 30 to 162mm in diameter, are available for high resolution volume susceptibility measurements on whole cores. They are suitable for measuring any type of peat, lake or marine sediment core, provided it is not metal clad.

These rugged sensors, with a very low temperature induced drift, are designed for laboratory, field or shipboard use. They can be used with manual or automated core analysis systems – details can be provided.

The MS2C Sensors are used in prospection, core correlation and the identification of palaeoclimatic sequences. Optimum measurement accuracy is achieved with 5 to 10mm core clearance. Calibration graphs are provided for varying core to sensor diameter.

Specification - MS2C Sensor

Loop internal diameter	30, 36, 40, 45, 47, 50, 60, 70, 72, 80, 85, 90, 93, 100, 110, 120, 125, 130, 135, 140, 145, 146, 150, 160 or 162mm (Intermediate sizes can be provided at an additional charge)
Calibration accuracy	5% (calibration sample provided)
Measurement period: x 1 range x 0.1 range	1.1s SI (0.9s CGS) 11s SI (9s CGS)
Operating frequency	0.565kHz
Drift at room temperature	$<2 \times 10^{-5}$ SI (vol) ($<2 \times 10^{-6}$ CGS) in 10 minutes (after 5 minutes' warm-up)
Dimensions (H x W x D)	290 x 200 x 160mm
Weight	2 to 2.7kg depending on diameter
Enclosure material	White polyacetal



MS2D Surface Scanning Probe

This loop probe is designed for rapid assessment of the concentration of ferromagnetic materials in the top 100mm of the land surface. It is used in studies of slope processes and in archaeological prospecting. The probe can only be operated in conjunction with the MS2 Probe Handle.

Specification - MS2D Probe

Depth of response	50% at 15mm, 10% at 60mm
Measurement period: x 1 range x 0.1 range	0.6s SI (0.5s CGS) 6s SI (5s CGS)
Operating frequency	0.958kHz
Drift at room temperature	$<10 \times 10^{-5}$ SI (vol) ($<10 \times 10^{-6}$ CGS) in 20 minutes (after 20 minutes' warm-up)
Dimensions: overall coil	208mm diameter x 90mm height 185mm mean diameter
Weight	0.5kg
Enclosure material	Reinforced epoxy

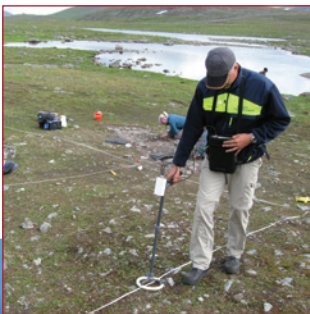

MS2E Core Logging Sensor

This sensor is designed to perform high resolution measurements on the surface of split drill or soft sediment cores. The sensitive area of the probe, as defined by 50% maximum response, is in the form of a rectangle of 3.8mm x 10.5mm, allowing very fine resolution surface measurements. The position of the long axis is identified by marks on the circumference of the sensor. The MS2E is supplied in a protective case.



Specification - MS2E Sensor	
Area of response	3.8mm x 10.5mm at the end of the ceramic cylinder
Depth of response	50% at 1mm, 10% at 3.5mm
Measurement period: x 1 range x 0.1 range	1.5s SI (1.2s CGS) 15s SI (12s CGS)
Operating frequency	2kHz
Drift at room temperature	<5 x 10 ⁻⁵ SI (vol) [<5 x 10 ⁻⁶ CGS] in 5 minutes (after 5 minutes' warm-up)
Dimensions (H x W x D)	150 x 50 x 25mm
Weight	0.22kg
Enclosure material	Diecast aluminium and ceramic

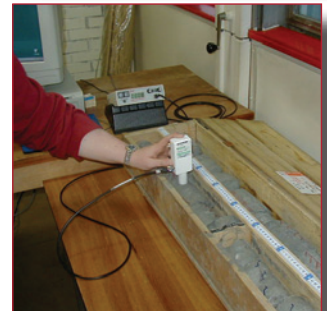

MS2F Surface Point Probe

This miniature probe is ideal for the stratigraphic study of exposed geological and archaeological sections. It is also used where uneven surface conditions prevent good contact with the MS2D loop. The MS2F can only be operated when connected to the MS2 Probe Handle.



Specification - MS2F Probe	
Area of response	End face and cylinder wall up to the shoulder
Depth of response	10% at 6mm from end face and 4.5mm from outer diameter of end cap
Measurement period: x 1 range x 0.1 range	1.1s SI (0.9s CGS) 11s SI (9s CGS)
Operating frequency	0.58kHz
Drift at room temperature	<10 x 10 ⁻⁵ SI (vol) [10 x 10 ⁻⁶ CGS] in 20 minutes (after 20 minutes' warm-up)
Dimensions: sensitive volume overall	15mm diameter x 20mm 35mm diameter x 85mm
Weight	0.05kg
Enclosure material	Nylon 66



MS2G Single Frequency Sensor

This sensor is designed for magnetic susceptibility measurements of 1ml liquid or powder samples. Calibrated volume is 1ml, but scaling correction values allow volumes down to 0.2ml to be measured. The sensor operates at a low frequency and has excellent temperature stability.

The MS2G is used for susceptibility measurements where only very small samples of homogeneous fine-grained material are available. Examples are airborne particulates collected in filter papers or particles in colloidal suspension.

The sensor accepts commercially available polythene vials with a diameter of 8mm and a length of 30mm. The sample holder is compatible with other rock measuring equipment, allowing a comprehensive range of measurements to be taken without the need for re-packing the sample. The sample cavity is situated at the tip of a boom mounted on the aluminium electronics enclosure.

Specification - MS2G Sensor	
Calibration accuracy	2% (1ml calibration check sample provided)
Measurement period: x 1 range x 0.1 range	0.9s SI (0.7s CGS) 9s SI (7s CGS)
Operating frequency	1.3kHz
Drift at room temperature	$<2 \times 10^{-5}$ SI (vol) [$<2 \times 10^{-6}$ CGS] in 5 minutes (after 5 minutes' warm-up)
Sample cavity dimensions	8.5mm diameter x 28mm in height
Sensitive region	5mm height at centre of cavity
Dimensions (H x W x D)	69 x 93 x 185mm
Weight	0.67kg
Enclosure material	Aluminium and ceramic
Sample vial: 1ml volume	Kartell part number 730



MS2K Surface Sensor

This handheld sensor is designed to provide highly repeatable measurements of the volume magnetic susceptibility of moderately smooth surfaces. Applications include description of magnetic stratigraphy and identification of horizons. It can also be used for characterisation of outcrops and logging split cores, with the exception of metal-clad cores. The sensor has applications in materials testing where the relatively low operating frequency permits measurement on some of the less electrically conductive metal alloys, for example stainless steel, without magnetisation.

Specification - MS2K Sensor	
Area of response	25.4mm diameter (full-width, half-maximum)
Depth of response	50% at 3mm, 10% at 8mm
Measurement period: x 1 range x 0.1 range	1.2s SI (1s CGS) 12s SI (10s CGS)
Operating frequency	0.93kHz
Drift at room temperature	$<2 \times 10^{-5}$ SI (vol) [$<2 \times 10^{-6}$ CGS] in 5 minutes (after 5 minutes' warm-up)
Environmental	May be used under wet conditions – not suitable for immersion
Dimensions (H x W x D)	170 x 165 x 50mm
Weight	0.32kg (1.20kg with carrying case)



MS2H Downhole Sensor

The MS2H is a downhole sensor for profiling the magnetic susceptibility of strata in 25mm nominal diameter auger holes. The detachable probe is fitted to the lower end of a push-tube to give an assembled length of 1 metre. Waterproof screw couplings allow further 1-metre extension tubes to be added to achieve any practical length. The probe assembly is hand guided within the hole during logging and graduations ensure depth control to a resolution of 1cm. The probe connects to the meter via a 5mm diameter cable, which may be extended to any practical length up to 100m.



The region of magnetic investigation radiates uniformly around the end of the probe, resulting in tolerance to inhomogeneities. Strata as narrow as 12.5mm in thickness can be discriminated. Measurements to a resolution of 1×10^{-5} SI (volume) are obtained in less than one second. A low operating frequency of 1.3kHz ensures immunity to electrical conductivity effects.

Suitable augers can be supplied – more information on request.

Applications include cultural stratigraphy in archaeology, geomorphology, landslide characterisation, paleosol identification, pedology, erosion studies and stratigraphic correlation.

Specification - MS2H Sensor	
Spatial resolution (vertical)	12.5mm (full-width, half-maximum)
Depth of horizontal penetration	50%/2mm, 10%/5.5mm, 1%/13mm
Pattern of investigating field	Isotropic radial
Operating frequency	1.3kHz
Resolution	1×10^{-5} SI (1×10^{-6} CGS)
Calibration accuracy	5% in $\varnothing 22$ mm sample
Measurement period (x1 range)	0.9s SI (0.7s CGS)
Thermal drift (typical)	2×10^{-5} SI/ $^{\circ}$ C (below 20 $^{\circ}$ C) -1×10^{-5} SI/ $^{\circ}$ C (above 20 $^{\circ}$ C)
Thermal setting time (typical)	30s/ $^{\circ}$ C (step change)
Markings for plane of sensitivity	Lowest graduation
Probe	
Diameter	21.5mm
Length	153mm
Weight	0.13kg
Connector type	TNC
Push tubes	
Construction	Anodised aluminium alloy with BS015 'O' ring seal and stainless steel threaded couplings
Lengths including union:	
extension	101.5cm
primary	91.5cm
Weight	0.35kg each
Connecting cable	
Construction	10m length, 5mm diameter co-axial (may be extended to 100m max)
Weight	0.4kg/10m
Carrying case	
Dimensions (H x W x D)	140 x 1380 x 380mm
Weight (full)	10kg

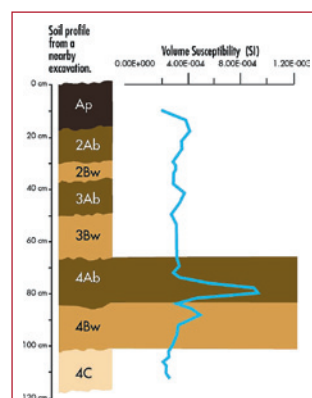
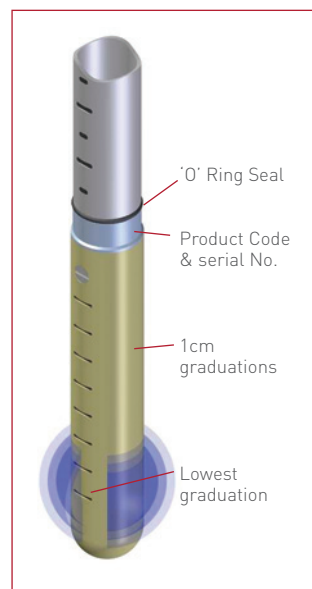

Down-hole measurements at the Canning Archaeological Site (USA) recording multiple paleosols (2Ab, 3Ab) and buried occupation layer (4Ab, 4Bw)

MS2 Probe Handle

This device incorporates the electronics for both the MS2D and MS2F and is required for connection of these sensors to the meter. The handle is submersible to the depth of the electronics unit (0.6m).



Specification - MS2 Probe Handle

Dimensions: upper section	430mm length
lower section	360mm length
Weight	0.6kg

MS2 Equipment Carrying Case

This is a tough lockable case with cut-outs to provide maximum protection for the equipment. Different cases are available, to suit the combination of instruments ordered.

Specification - Equipment Carrying Case

Maximum dimensions (H x W x D)	285 x 690 x 500mm
Weight	8 to 10kg including equipment
MS2, MS2D, MS2F and Probe Handle Carrying Case	
Dimensions (H x W x D)	230 x 620 x 510mm
Weight	10kg including equipment
MS2 Susceptibility/Temperature System Carrying Case	
Dimensions (H x W x D)	310 x 710 x 570mm
Weight	18.6kg including equipment





MS2/MS3 Susceptibility/Temperature System

This system measures the magnetic susceptibility of samples over the temperature range -200°C to $+850^{\circ}\text{C}$. It is used in the investigation of the magnetic properties of minerals and for the determination of Curie transition temperatures.

The system comprises the MS2 or MS3 Meter, MS2W Water Jacketed Sensor, MS2WF Furnace, MS2WFP Power Supply Unit and a self-contained water coolant supply, fully interlocked to prevent the MS2WF Furnace operating without coolant flow. The Geolabsoft software package (running under Windows®) collects data and displays the results during the measurement sequence.

MS2W Water Jacketed Sensor

This water jacketed sensor has a 30mm diameter sample cavity. The temperature stability of the sensor is excellent and drift during the measurement sequence is exceptionally low as the water jacket thermally isolates the electronics from the sample cavity. The sensor can be used without the furnace or power supply, in conjunction with the MS2/MS3 Meter and a non-magnetic type T thermocouple (Cu/Cu-Ni), for measurements on 10ml cylindrical samples over the temperature range -200°C to room temperature. The sample is cooled in liquid nitrogen and allowed to warm slowly to room temperature while measurements are taken.



For high temperature measurements to $+850^{\circ}\text{C}$, the MS2WF Furnace and MS2WFP Power Supply Unit are required.

Specification - MS2W Sensor	
Measurement sensitivity	1×10^{-5} SI (vol) (1×10^{-6} CGS) for 10ml sample, reduced by a factor of 4 for 2.5ml sample
Calibration accuracy	1% (calibrated for 10ml sample)
Measurement period: x 1 range x 0.1 range	2.4s SI (1.9s CGS) 24s SI (19s CGS)
Operating frequency	0.696kHz
Drift during measurement	$<2 \times 10^{-5}$ SI (vol) ($<2 \times 10^{-6}$ CGS)/30 minutes with 2l/minute water flow through sensor
Dimensions: probe internal overall (H x W x D)	$\varnothing 30\text{mm}$ 65 x 100 x 255mm
Weight	0.85kg



MS2WF Furnace

The MS2WF Furnace is installed inside the cavity of the MS2W Water Jacketed Sensor for heating samples from room temperature to +850°C. The non-inductively wound platinum heating element on a quartz cylinder ensures uniform heating of the sample, while insulation reduces the maximum external temperature to around 100°C.

The sample temperature is displayed on a digital panel meter to a resolution of 0.1°C when connected to a thermocouple – either type S (Pt/Pt-Rh: for measurements up to +850°C) or type T (Cu/Cu-Ni: for measurement in the range -200°C to +350°C). The sample temperature is also available as an analog voltage.

The sample diameter is restricted to 15mm maximum or circa 2.5ml volume. A ceramic crucible, specially designed to fit onto the thermocouple, is provided for granular or powder samples.

Specification - MS2WF Furnace

Dimensions: overall (H x W x D)	350 x 135 x 235mm
heating cavity	17mm ID 25mm usable height
ceramic crucible cavity	13mm ID 20mm usable height
Weight	2kg



MS2WFP Power Supply Unit

This unit supplies power to the MS2WF Furnace to heat the sample. The sample temperature can be increased or decreased at a pre-selected linear rate or maintained at a pre-set level using manual controls.

Specification - MS2WFP Power Supply Unit

Dimensions (H x W x D)	165 x 317 x 210mm
Weight	7kg



Software

Bartsoft

The MS3 Meter has no display or controls because it is designed to be connected to a PC, laptop or PDA running the supplied Bartsoft software. This provides a range of features to control the meter and display the measured results.

Main Features

- Adjustable measurement period to optimise the overall time taken and the required data resolution. This can more than halve the overall experimental time, compared to older MS2 Meter systems.
- User-definable measurement protocols can be used to provide a level of automation in the measurement process. Predefined protocols are available for tasks such as individual sample tests, core logging, two-dimensional X-Y surveys and one-dimensional downhole surveys.
- Data display options including tabular format, with selectable data columns and X-Y chart plots.
- Automatic correction factors for non-standard sample volume, mass specific results and temperature drift.

Data collected can be saved in Bartsoft's native format or copied into other applications (e.g. spreadsheets) for further analysis.

Versions available:

- Bartsoft for Windows requires Windows 2000/XP/Vista or Windows 7 (both 32-bit and 64-bit).
- Bartsoft for Windows CE runs under Windows Mobile 6 and includes GPS compatibility, enabling magnetic susceptibility data to be tagged with a GPS location (this requires a Windows Mobile device with internal or external GPS).

Note that Bartsoft for Windows can be used with the MS2 Meter. Most features will function, although the measurement period is fixed at 1.0s or 0.1s by the meter. Bartsoft for Windows CE will not operate with the MS2 Meter.

AMSWIN-BAR

This package is used with the MS2 Meter and MS2B Sensor to measure the anisotropy of magnetic susceptibility for magnetic fabric analysis. A sample adaptor designed for 25mm diameter palaeomagnetic samples is supplied with the software.

The software operates under Windows 2000/XP/Vista. Note that the MS3 Meter does not operate with the AMSWIN-BAR.

Geolabsoft software

This software for the MS2/MS3 Susceptibility/Temperature System runs under Windows 95/98/2000/NT/XP/Vista. Data is collected via a single RS232 serial interface and plotted in real time. Drift correction is applied at the end of the measurement sequence.

Bartington[®]
Instruments

Bartington Instruments Limited
5, 10 & 11 Thorney Leys Business Park
Witney, Oxford, OX28 4GE, England.

Brazil
www.alphageofisica.com.br
Email: info@alphageofisica.com.br
Tel.: 21 3507-7665

Bartington[®] is a registered trademark of Bartington Instruments Ltd.
Windows[®] and Windows Vista[®] are registered trademarks of Microsoft.

The specifications of the products described in this brochure are subject to change without prior notice. Specifications for all Bartington Instruments' products are available on the Internet.

www.bartington.com